

**TWIST, TURN & LIFT**  
 To Any Position



**EDGE MOUNT  
 DOUBLE ARM**



**SCREEN ROTATION**  
 360°



**VESA COMPATIBLE**  
 75 X 75 & 100 x 100



**SCREEN SIZE**  
 15" to 27"



**SWIVEL RANGE**  
 +90° to -90°

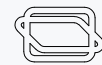

**TILT RANGE**  
 +60° to -85°



**LOAD CAPACITY**  
 6kgs/arm

## FEATURES

- CMA double extension arm is now available with **EDGE MOUNT** variation.
- Practical solution for work from home, commercial spaces, security offices, health care environments, etc.
- **Table top thickness: 18-60mm**
- Concealed cable management system enables clutter free work desk.
- Finish: White Texture, Anthracite

## SPECIFICATION

CODE	FINISH	PCS./ SET	MRP* (₹)
CMADA-EAEM	WT/ AT	Each	5,316

\*Subject to change without prior intimation.

WT: White texture  
 AT: Anthracite

**TWIST, TURN & LIFT**  
 To Any Position



**EDGE MOUNT  
 DOUBLE ARM**



**SCREEN ROTATION**  
 360°



**VESA COMPATIBLE**  
 75 X 75 & 100 x 100



**SCREEN SIZE**  
 15" to 27"



**SWIVEL RANGE**  
 +90° to -90°



**TILT RANGE**  
 +60° to -85°



**LOAD CAPACITY**  
 6kgs/arm

## FEATURES

- CMA double arm is now available with **EDGE MOUNT** variation.
- Practical solution for work from home, commercial spaces, security offices, health care environments, etc.
- **Table top thickness: 18-60mm**
- Concealed cable management system enables clutter free work desk.
- Finish: White Texture, Anthracite

## SPECIFICATION

CODE	FINISH	PCS./ SET	MRP* (₹)
CMADA-EM	WT/ AT	Each	4,532

\*Subject to change without prior intimation.

WT: White texture  
 AT: Anthracite

# COMPUTER MONITOR ARM

## DOUBLE ARM/ DOUBLE EXTENSION ARM **EDGE MOUNT**

### LINE DRAWINGS:

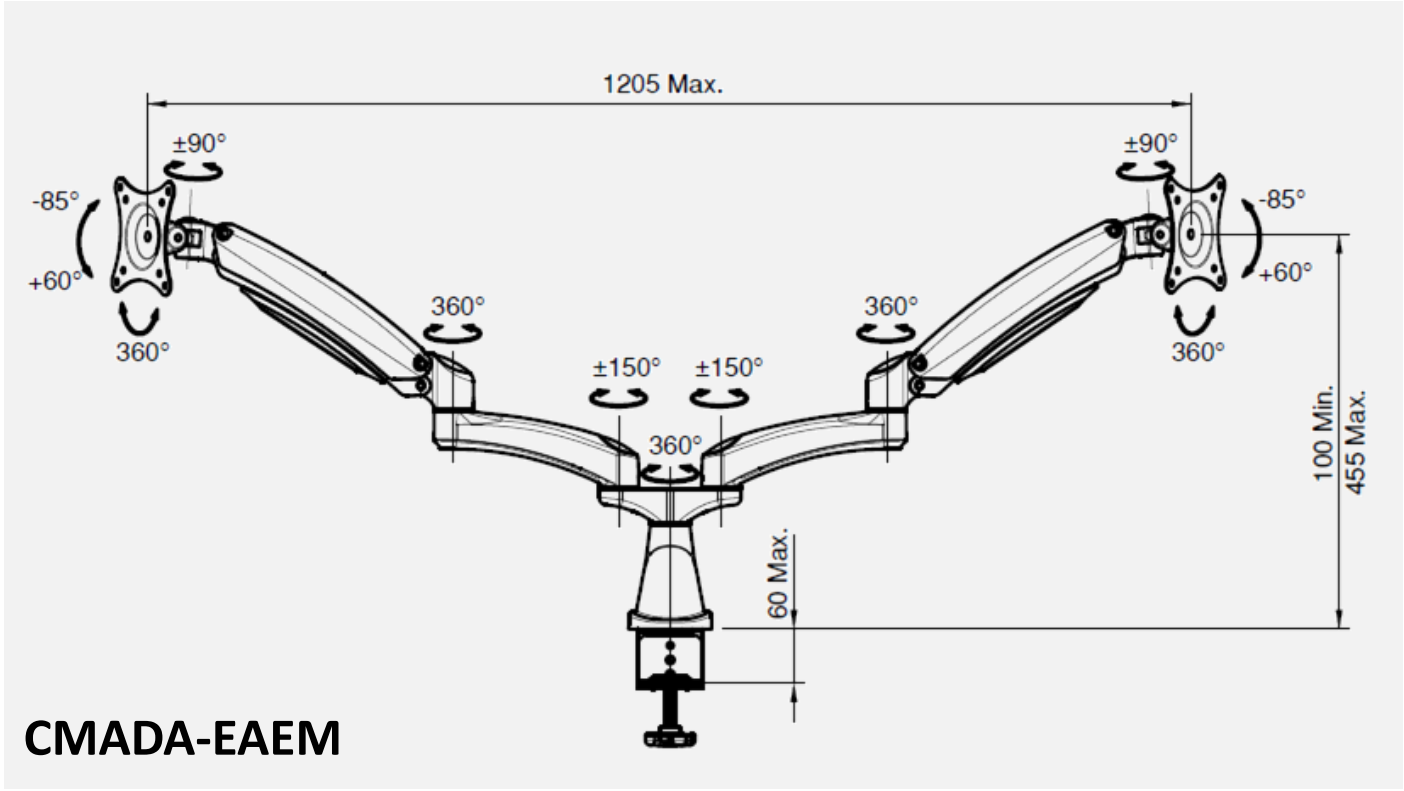

**CMADA-EAEM**

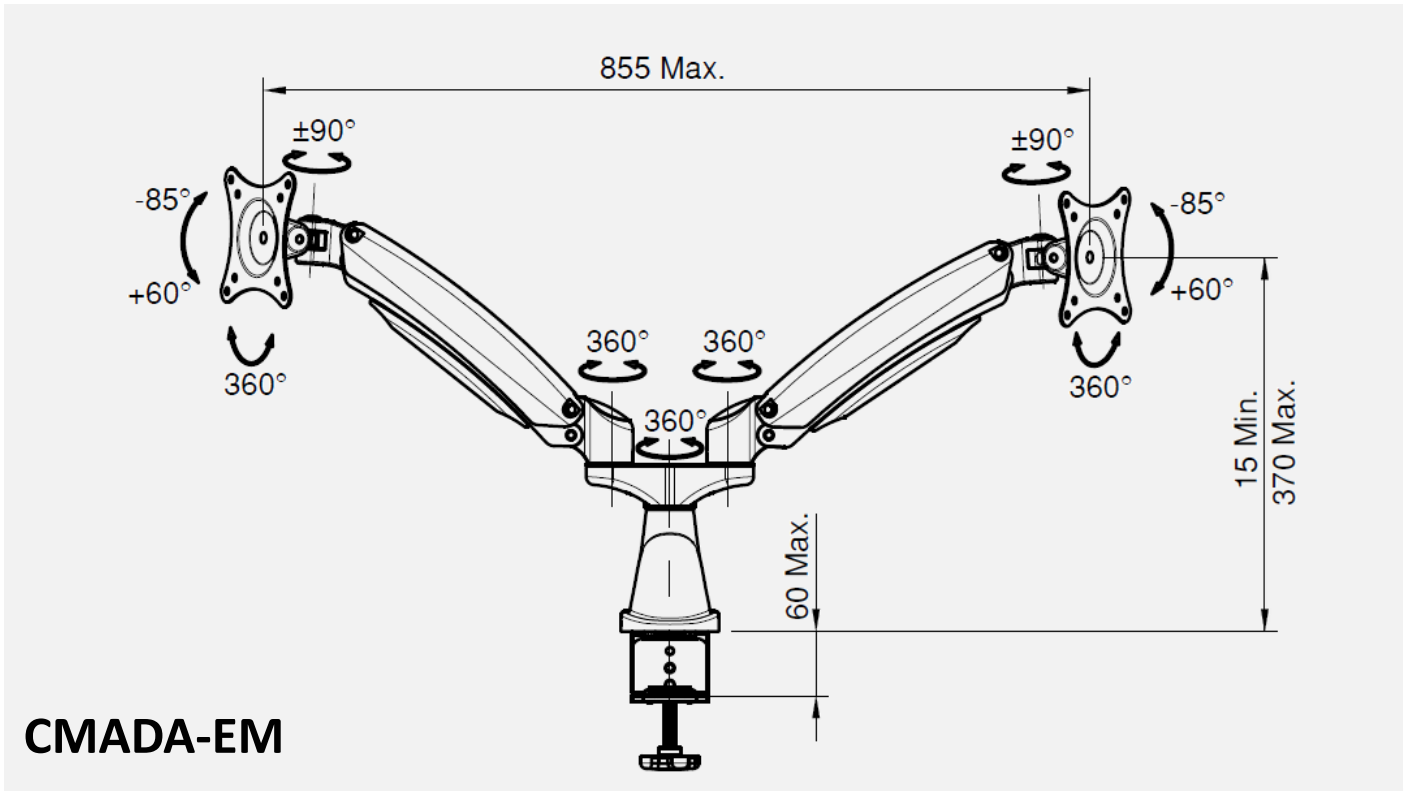

**CMADA-EM**